

REDLER ISO CONTAINER LOADER SYSTEM FOR DRY BULK PRODUCTS



March, 05

Data Sheet No. 017

- Ø Supplied “READY TO GO”
- Ø Well proven equipment
- Ø Rapid loading
- Ø Quick connection to container
- Ø Easy operation and cleaning
- Ø Maximum pay load per container
- Ø Minimal manpower required
- Ø Suitable for loading 20ft, 30ft & 40ft containers
- Ø Product contact materials in stainless steel
- Ø Fully integrated control panel
- Ø Optional fan and seal - used for inflatable liners
- Ø ATEX 22 version available



Transportation of Bulk Materials in ISO Containers is growing rapidly, but the loading and unloading of containers remains a major bottleneck.

This is where Redler is able to step in and help you reduce standing time for vehicles in your bulk handling operation.

We have solved these time consuming loading problems by adapting our well-proven High Speed Thrower. The Container Loader System has been engineered and applied to satisfy the combined needs of both the logistics industry as well as the suppliers of bulk products.

With a throughput capacity in excess 100 tonnes per hour, giving loading rates for example of 18 tonnes of plastic pellets in 20 minutes, our ‘Container Loader’ has been proven to greatly improve efficiency and reduce costs. It is fully supported by Redler Guarantees and after-sales service.



REDLER ISO CONTAINER LOADER SYSTEM FOR DRY BULK PRODUCTS

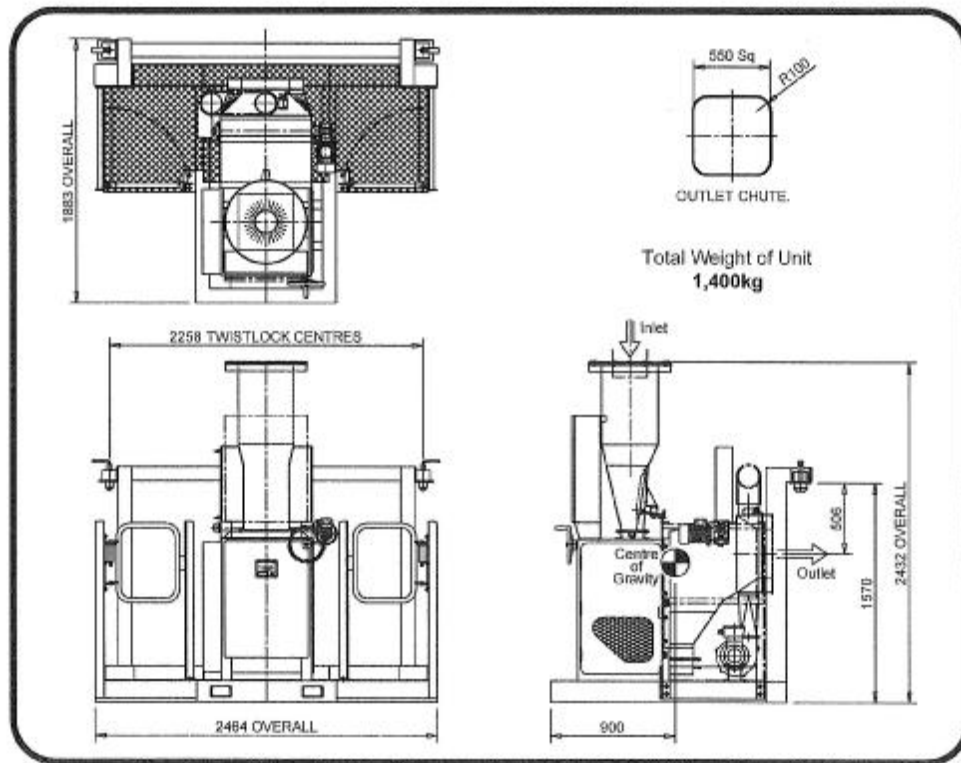
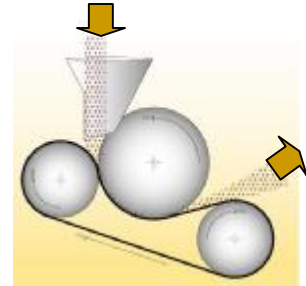
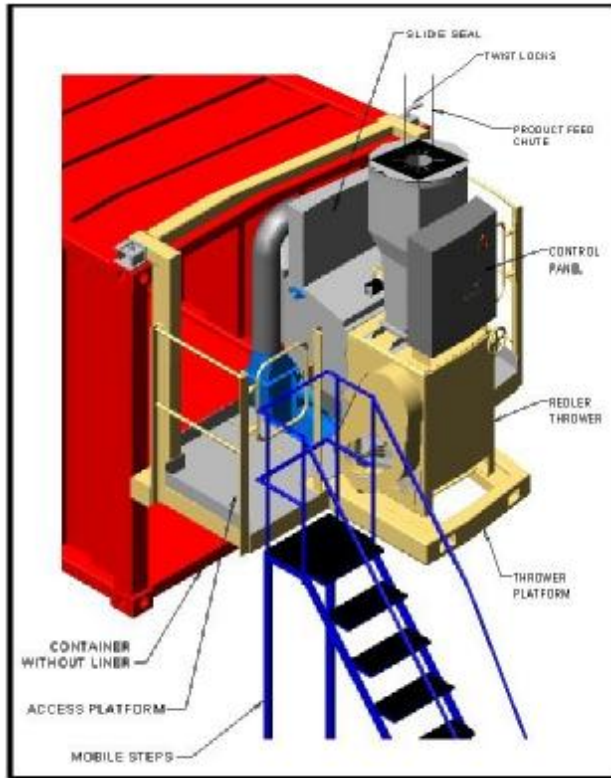

REDLER[®]

Redler Limited, Redler House, Dudbridge, Stroud, Gloucestershire GL5 3EY

STOCK[®]